

	30"	36"	42"	48"
DIM A	25 5/8	31 5/8	37 5/8	43 5/8

CUT-OFF INSTRUCTIONS FOR NON-STANDARD DOORS

1. DRIVE OUT TWO ROLL PINS.
2. REMOVE MOUNTING CAP.
3. COLLAPSE BAR AND TAPE DOWN IN THE AREA OF CUT-OFF.
4. DETERMINE EXTRUSION LENGTH ("B" DIM). (NOTE: 3 19/32" MINIMUM DIMENSION FROM RIVET CENTERLINE TO NEW CUTOFF LENGTH AS SHOWN).
5. MEASURE MOUNTING BAR (NOT PUSH BAR), AND MARK EXTRUSION LENGTH ON TAPE.
6. SAW OFF EXCESS LENGTH, REMOVE TAPE AND DEBURR.
7. LAY MOUNTING CAP OVER MOUNTING BAR (FIG. "C"), AND USE AS A GUIDE TO DRILL TWO 1/8" DIA HOLES.
8. RE-INSTALL MOUNTING CAP INTO MOUNTING BAR AND DRIVE TWO ROLL PINS INTO HOLES.

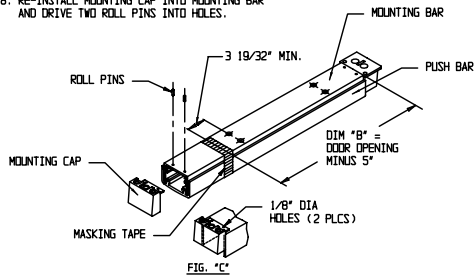
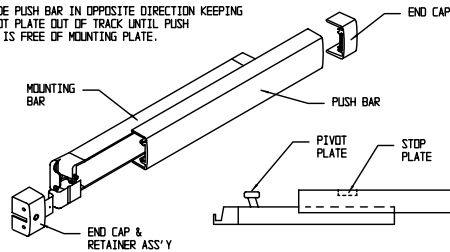

FIG. "C"

SEPARATING PUSH BAR AND MOUNTING BAR PROCEDURE

1. REMOVE BOTH END CAPS. THE RETAINER IS ATTACHED TO THE NOSE END CAP.
2. SLIDE PUSH BAR TOWARD HINGE SIDE OF DOOR.
3. CONTINUE TO SLIDE THE PUSH BAR PAST THE PIVOT PLATE THAT RIDES IN PUSH BAR TRACK.
4. SLIDE PUSH BAR IN OPPOSITE DIRECTION KEEPING PIVOT PLATE OUT OF TRACK UNTIL PUSH BAR IS FREE OF MOUNTING PLATE.



INSTALLING PUSH BAR TO MOUNTING BAR

1. WITH PUSH BAR IN HAND AND MOUNTING BAR ATTACHED TO DOOR, FIND STOP PLATE STAKED INTO PUSH BAR. (THIS PLATE IS ON THE LATCH END OF ASSEMBLED UNIT). SLIDE THE PIVOT PLATE NEAREST HINGE INTO TRACK OF PUSH BAR UNTIL SECOND PIVOT PLATE IS EXPOSED. INSERT PIVOT PLATE INTO TRACK ON PUSH BAR AND SLIDE IN OPPOSITE DIRECTION UNTIL PUSH BAR AND MOUNTING BAR ALIGN.

PREPARATION

NOTE: THESE DIMENSIONS AND TEMPLATES ASSUMES A DOOR THICKNESS OF 1 3/4". FOR DOORS OF OTHER THICKNESS, CONSULT FACTORY.

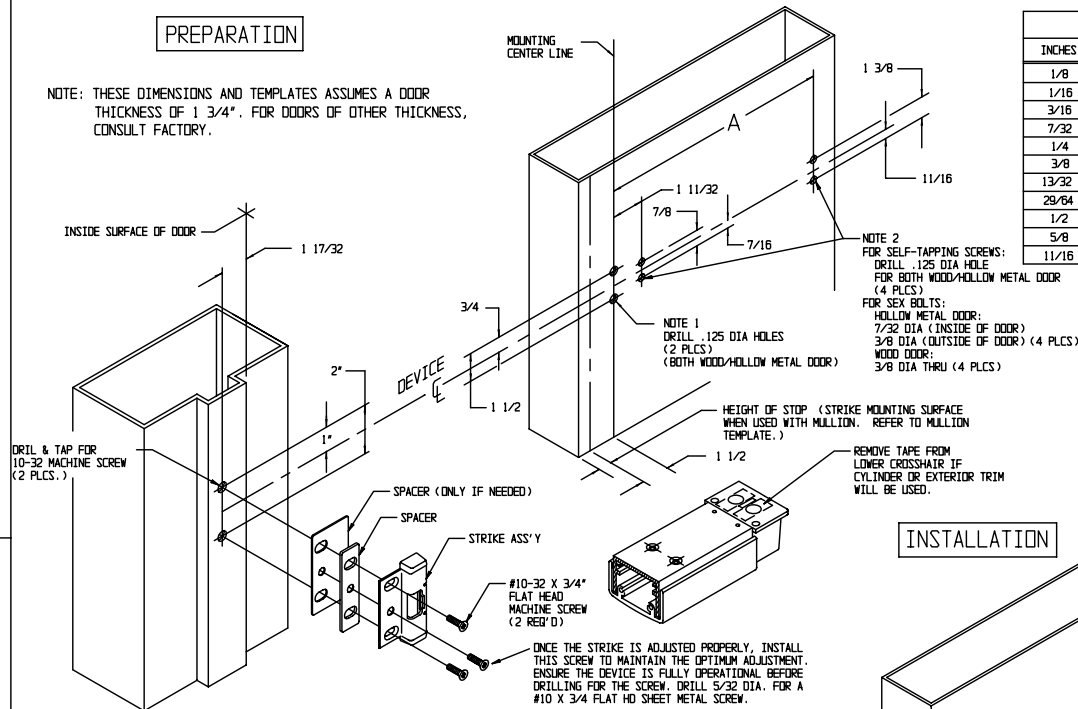

ADDITIONAL PREPARATION FOR OUTSIDE CYLINDER, IF REQUIRED

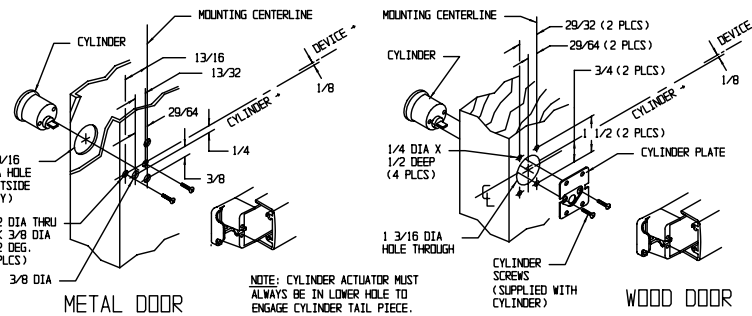

NOTE: CYLINDER ACTUATOR MUST ALWAYS BE IN LOWER HOLE TO ENGAGE CYLINDER TAIL PIECE.

METRIC EQUIVALENTS

INCHES	MM	INCHES	MM	INCHES	MM
1/8	3,17	3/4	19,05	3 19/32	91,29
1/16	1,59	13/16	20,64	5	127,00
3/16	4,75	29/32	23,03	24 9/32	616,74
7/32	5,56	1	25,40	30	762,00
1/4	6,35	1 3/16	30,15	30 9/32	769,14
3/8	9,53	1 3/8	34,93	36	914,40
13/32	10,31	1 1/2	38,10	36 9/32	921,54
29/64	11,51	1 17/32	38,89	42	1066,80
1/2	12,70	1 3/4	44,45	42 9/32	1073,94
5/8	15,88	2	50,80	48	1219,20
11/16	17,45	2 27/32	72,23		

INSTALLATION INSTRUCTIONS

(IF CYLINDER IS NOT USED, SKIP INSTRUCTIONS 1 AND 2).

1. INSTALL CYLINDER WITH CYLINDER PLATE.
2. INSTALL MOUNTING BAR (IF CYLINDER IS USED BE SURE THAT TAILPIECE PROTRUDES 3/16 INCH TO ENGAGE CYLINDER PROPERLY).
3. INSTALL PUSH BAR TO MOUNTING BAR. (SEE INSTRUCTIONS LOWER LEFT HAND CORNER).
4. INSTALL END CAPS.
5. INSTALL STRIKE AND STRIKE PLUG. USE ENOUGH SPACERS SO THAT STRIKE CLEARS END CAP BY 1/16".

INSTALLATION

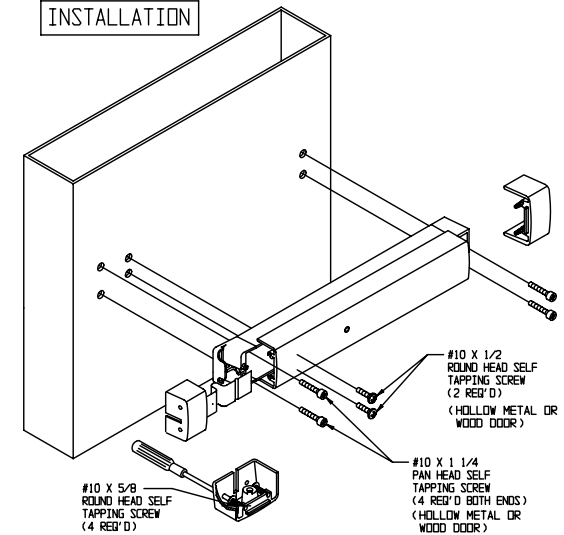

ADAMS RITE MANUFACTURING COMPANY
POMONA, CA. 91767

8700 RIM EXIT DEVICE
FOR WOOD OR HOLLOW METAL DOOR